



US007500041B2

(12) **United States Patent**
Danilak

(10) **Patent No.:** **US 7,500,041 B2**
(45) **Date of Patent:** **Mar. 3, 2009**

(54) **GRAPHICS PROCESSING UNIT FOR COST EFFECTIVE HIGH PERFORMANCE GRAPHICS SYSTEM WITH TWO OR MORE GRAPHICS PROCESSING UNITS**

(75) Inventor: **Radoslav Danilak**, Cupertino, CA (US)

(73) Assignee: **NVIDIA Corporation**, Santa Clara, CA (US)

(*) Notice: Subject to any disclaimer, the term of this patent is extended or adjusted under 35 U.S.C. 154(b) by 6 days.

7,007,025 B1 *	2/2006	Nason et al.	707/9
7,099,969 B2	8/2006	McAfee et al.	
7,412,554 B2	8/2008	Danilak	
2004/0233230 A1 *	11/2004	Hancock	345/690
2005/0088445 A1	4/2005	Gonzalez et al.	
2005/0140682 A1 *	6/2005	Sumanaweera et al.	345/506
2006/0005000 A1	1/2006	King et al.	
2006/0059451 A1 *	3/2006	Koehler et al.	716/17
2006/0098020 A1	5/2006	Shen et al.	
2006/0294279 A1	12/2006	McKee et al.	
2007/0139423 A1 *	6/2007	Kong et al.	345/502
2007/0214323 A1 *	9/2007	Moll et al.	711/135
2007/0294454 A1	12/2007	Danilak	

(21) Appl. No.: **11/454,991**

(22) Filed: **Jun. 15, 2006**

(65) **Prior Publication Data**

US 2007/0291039 A1 Dec. 20, 2007

(51) **Int. Cl.**
G06F 13/14 (2006.01)

(52) **U.S. Cl.** **710/305; 710/306**

(58) **Field of Classification Search** **710/305-306, 710/100; 711/135**

See application file for complete search history.

(56) **References Cited**

U.S. PATENT DOCUMENTS

6,956,579 B1	10/2005	Diard et al.
6,985,152 B2	1/2006	Rubinstein et al.

OTHER PUBLICATIONS

ATI CrossFire Technology White Paper, Jun. 14, 2005, 14 pages.

* cited by examiner

Primary Examiner—Clifford H Knoll

Assistant Examiner—Kim T Huynh

(74) *Attorney, Agent, or Firm*—Cooley Godward Kronish LLP

(57) **ABSTRACT**

A graphics processing unit is operable as an individual graphics processing unit. However the graphics processing unit has a mode of operation in which a private bus is formed with a second graphics processing unit.

14 Claims, 13 Drawing Sheets

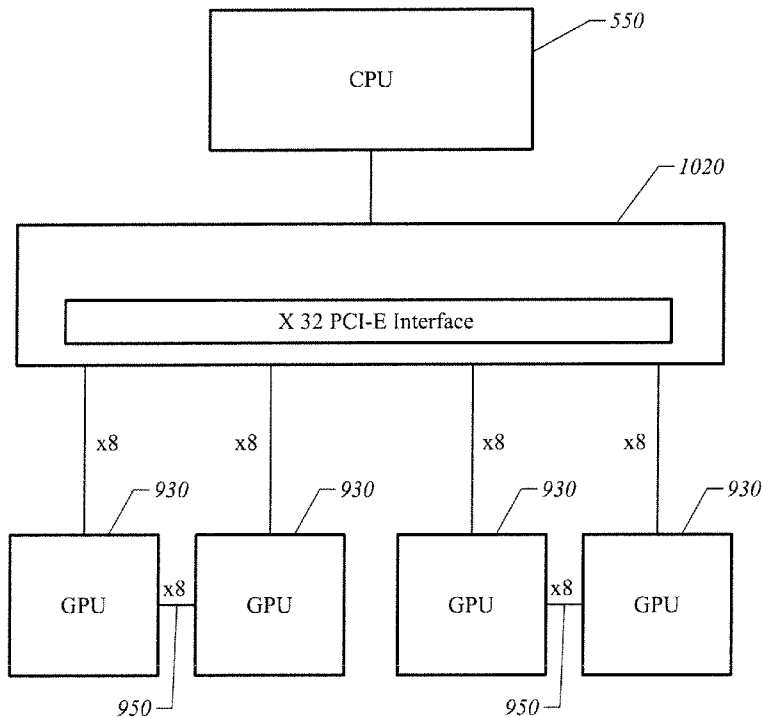

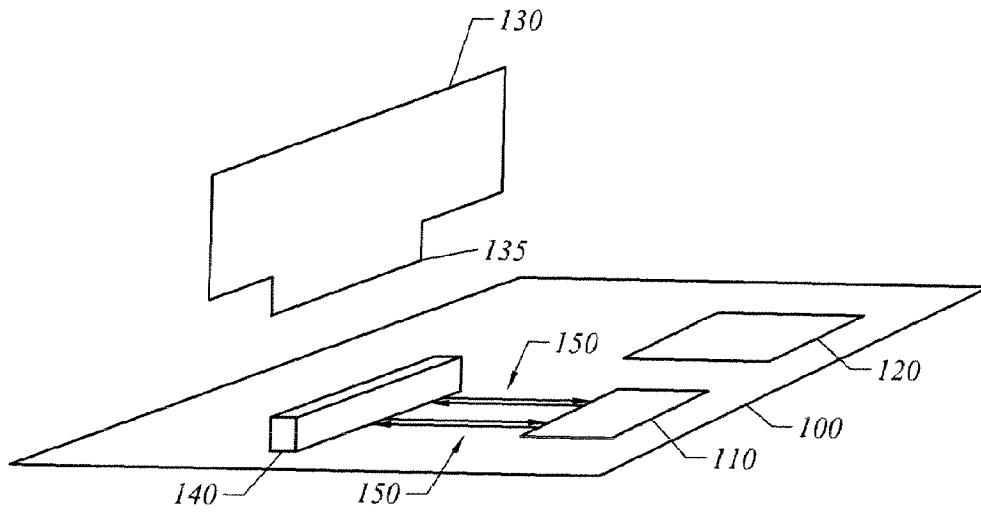

FIG. 1
(Prior Art)

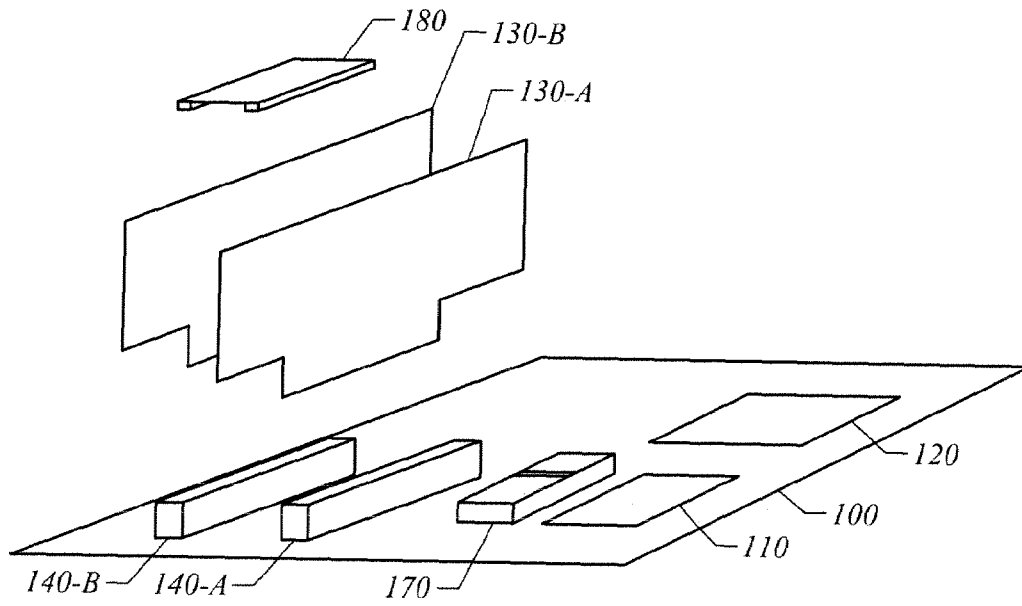

FIG. 2
(Prior Art)

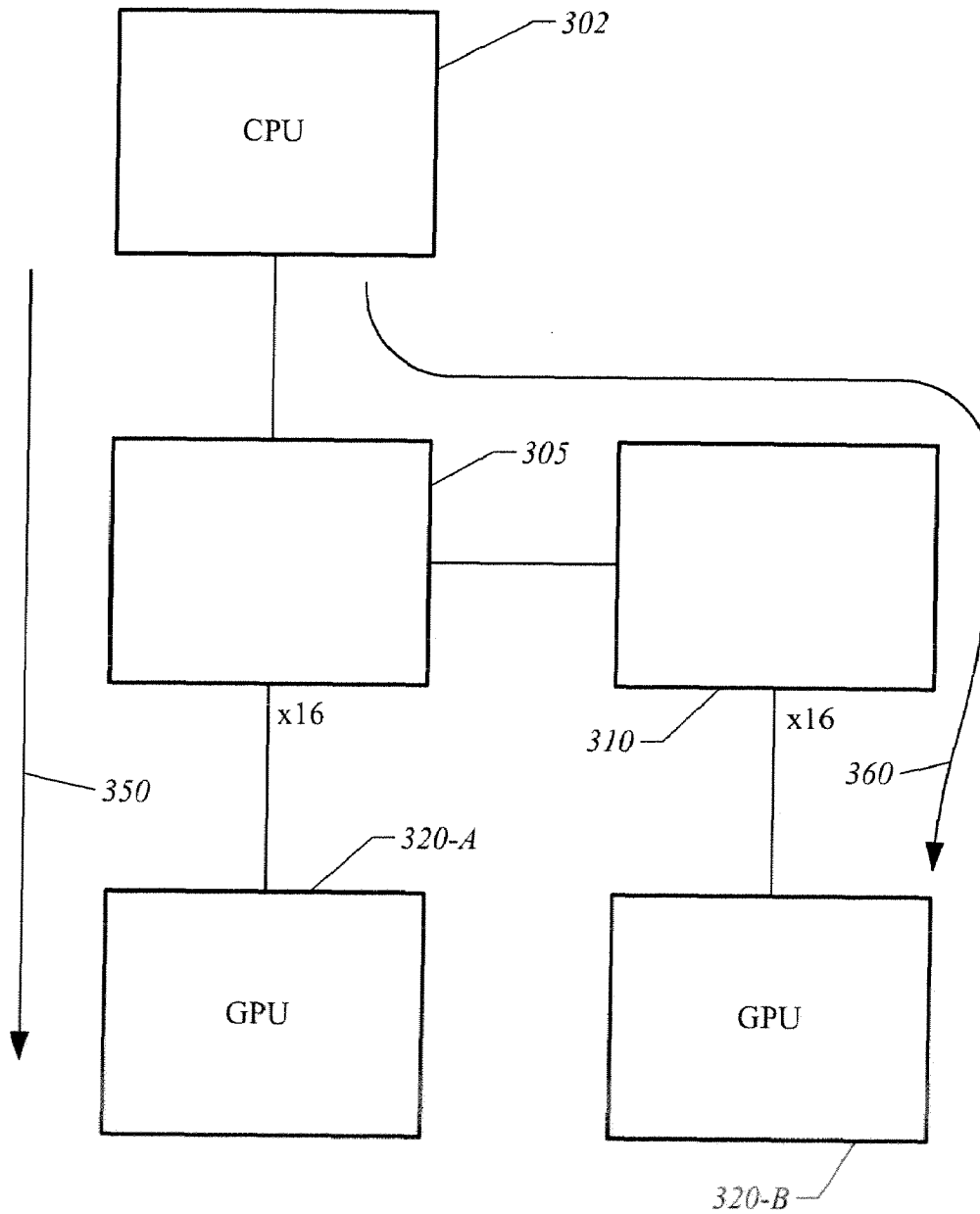

FIG. 3
(Prior Art)

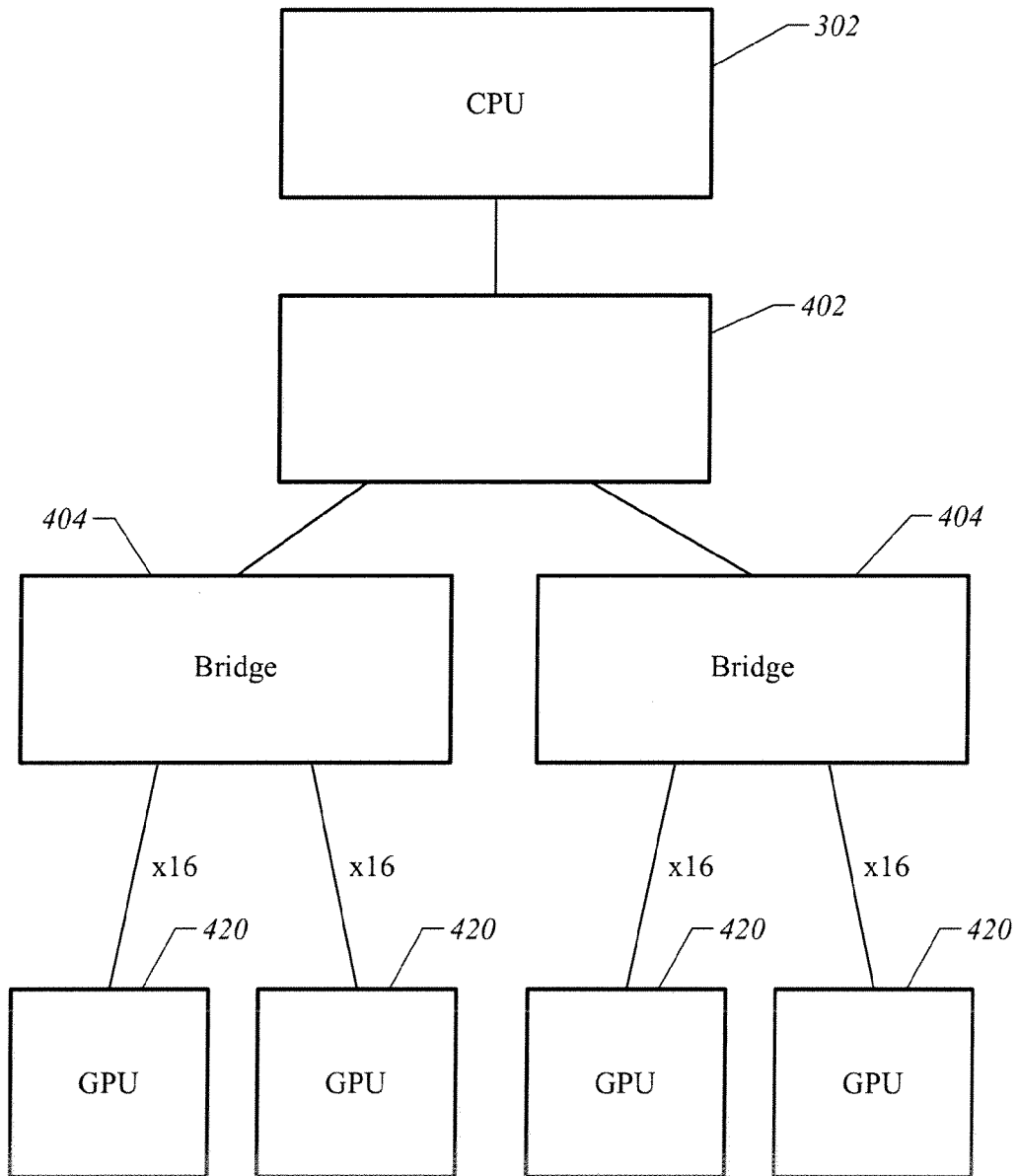
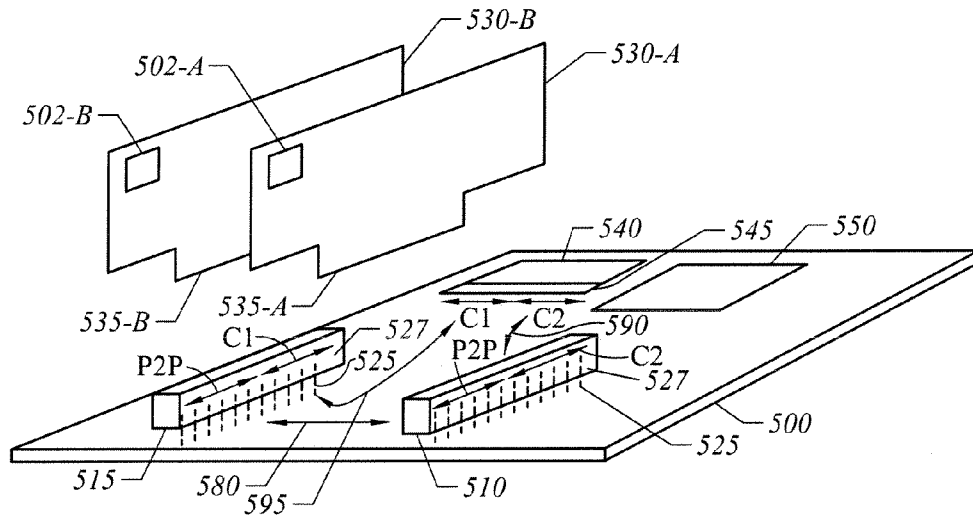

FIG. 4
(Prior Art)



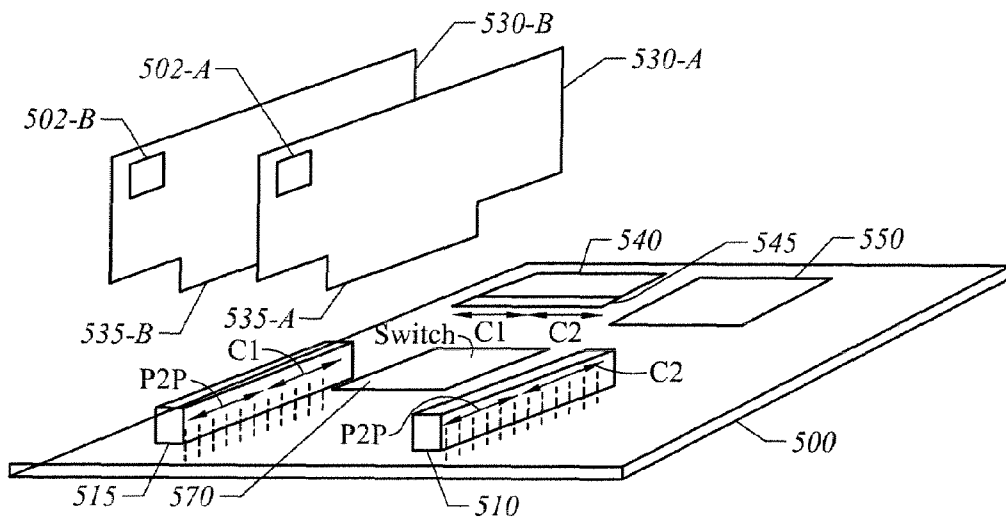

FIG. 6

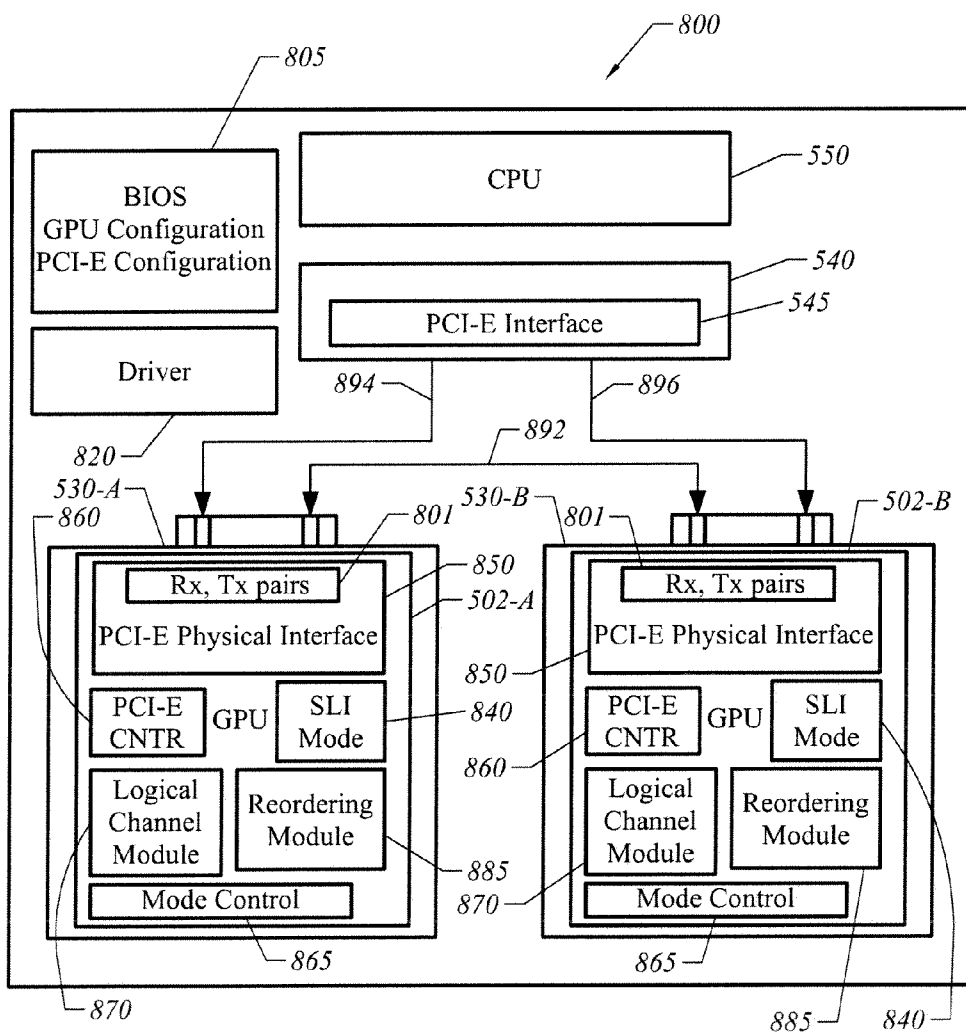

FIG. 8

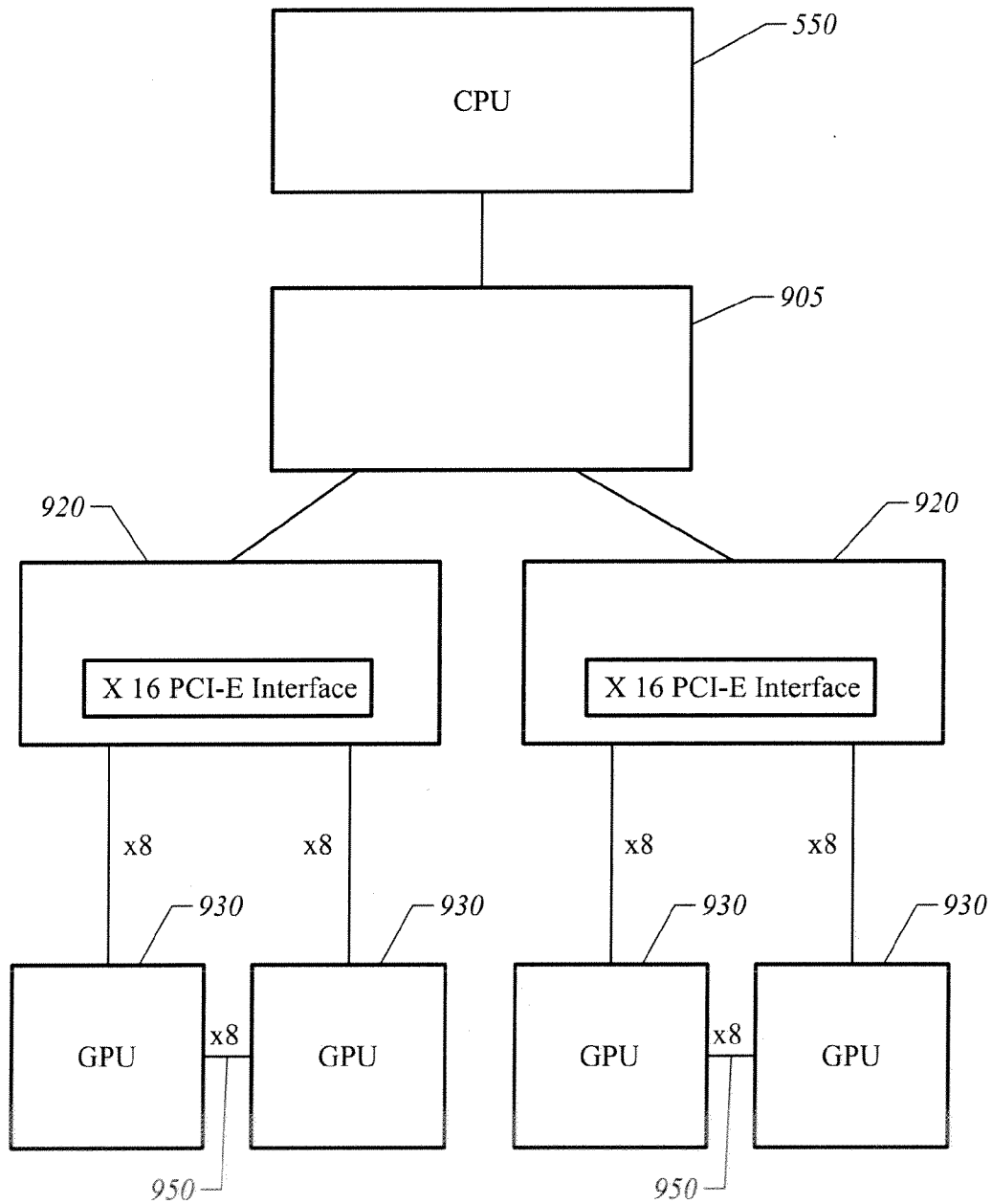

FIG. 9

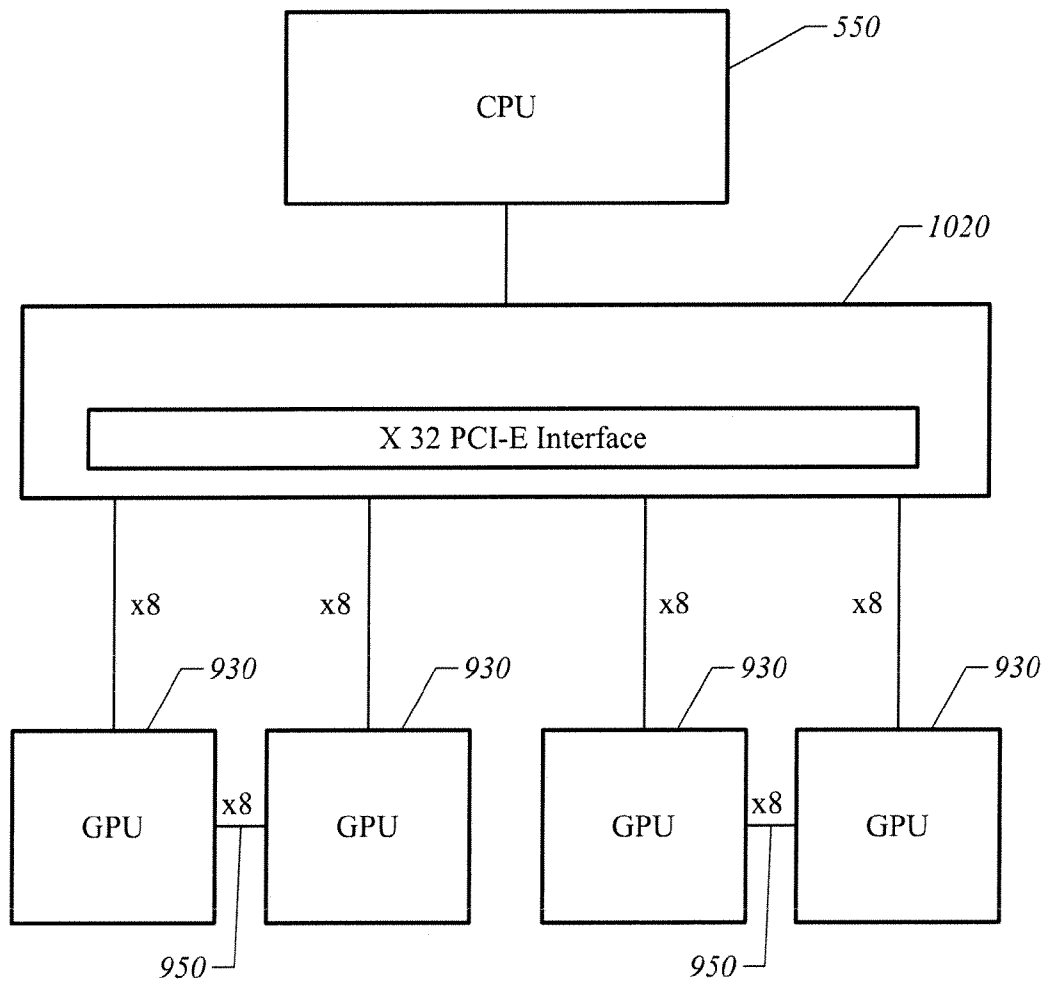

FIG. 10

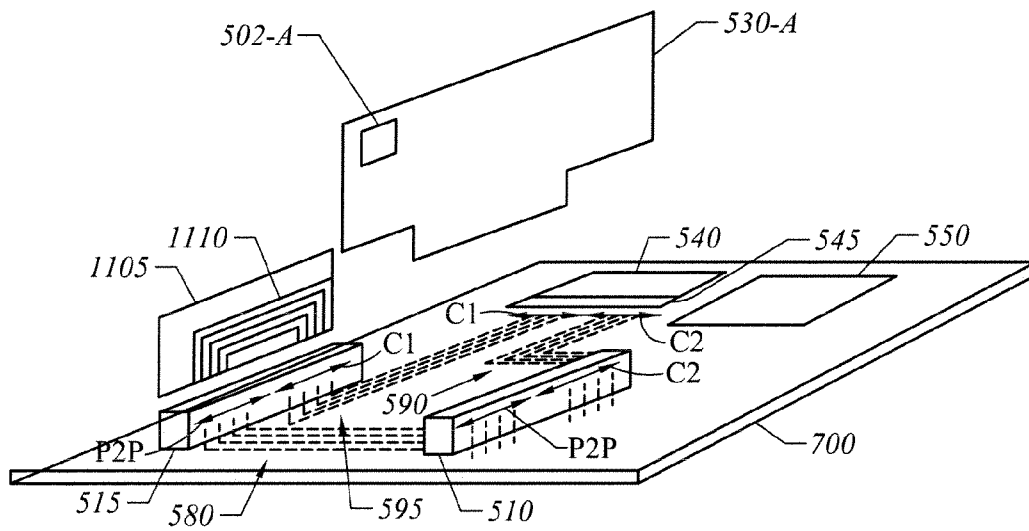

FIG. 11

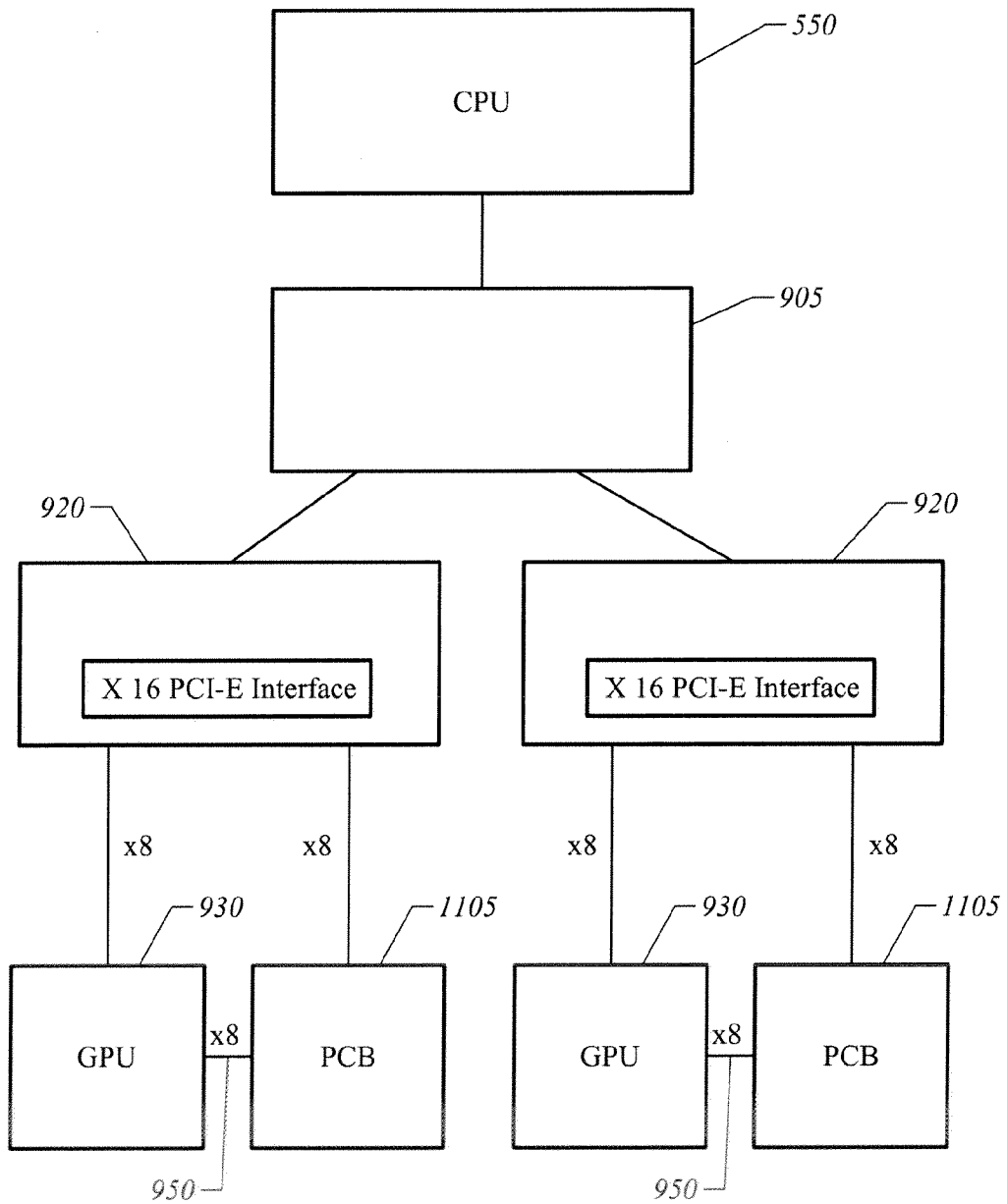

FIG. 12

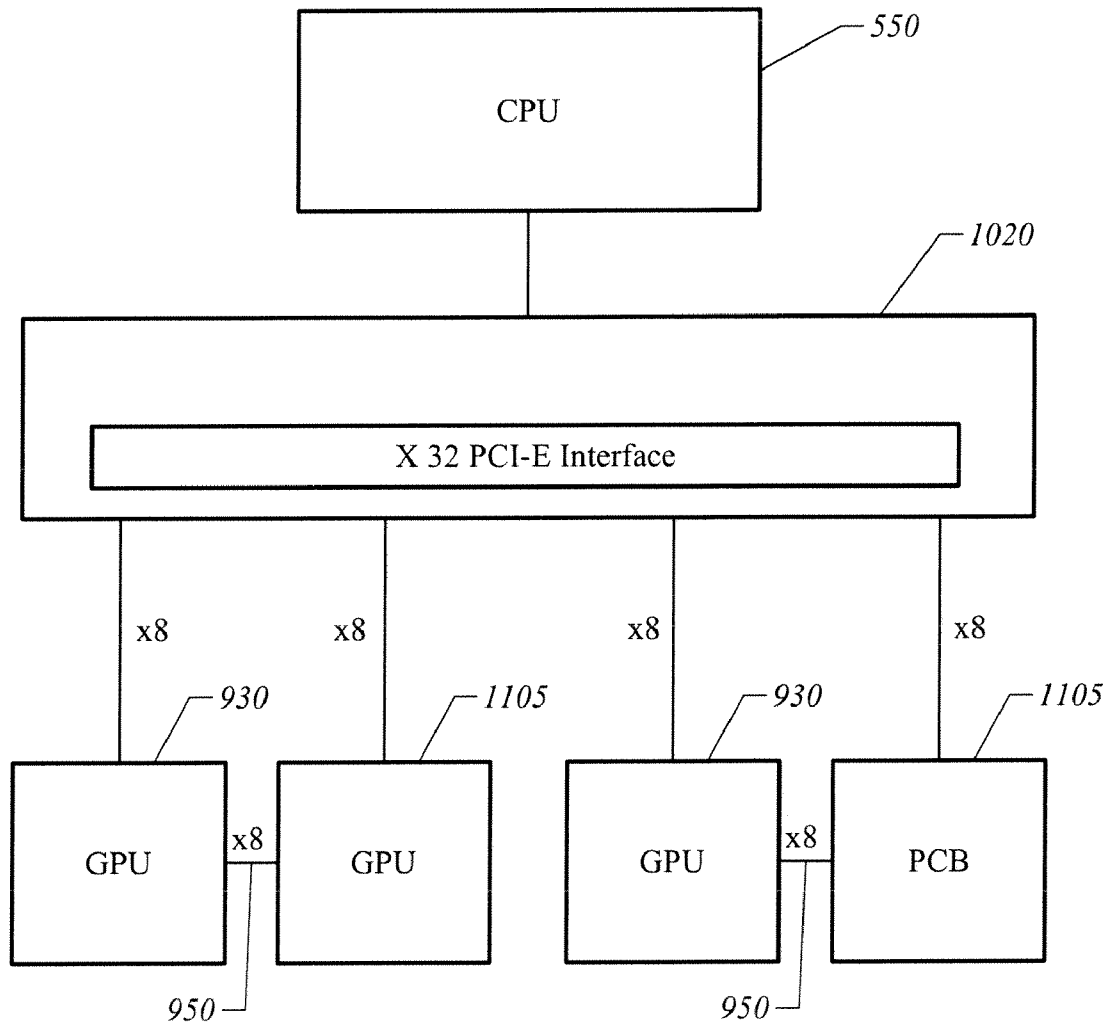

FIG. 13

**GRAPHICS PROCESSING UNIT FOR COST
EFFECTIVE HIGH PERFORMANCE
GRAPHICS SYSTEM WITH TWO OR MORE
GRAPHICS PROCESSING UNITS**

FIELD OF THE INVENTION

The present invention is generally related to graphics systems capable of supporting different numbers of graphics cards for improved performance. More particularly, the present invention is directed towards a private bus to support a cost-effective high performance graphics system.

BACKGROUND OF THE INVENTION

Graphics systems are typically implemented as a three-dimensional assembly of different cards (also sometimes called "boards") that are plugged into a motherboard. The motherboard is the main circuit board of the system and typically includes a central processing unit and other chips that are known as a "chipset." Additionally, a motherboard includes connectors, ports, and other features for attaching other electronic components.

Referring to FIG. 1, in a conventional graphics system a motherboard 100 includes a chipset that includes, for example, a bridge unit 110 and a central processing unit (CPU) 120. For the purposes of illustration, a graphics card 130 is illustrated in position for assembly. Graphics card 130 typically includes a graphics processing unit (GPU) (not shown). The graphics card 130 typically includes connector surfaces 135. For the purposes of illustration, a single connector surface 135 is illustrated that is designed to mate with a Peripheral Component Interface (PCI) Express (often referred to as "PCI-E" or "PCIe") connector 140. PCI-E is a high speed bus interface standard that utilizes high speed serial data lanes. The PCI-SIG organization publishes the PCI-E standard. An individual data lane 150 comprises two simplex connections, one for receiving data and the other for transmitting data.

The PCI-E standard specifies a protocol for bus interfaces to configure a set of data lanes into a link between two entities. The bandwidth of the link scales with the number of data lanes operated in parallel. The size of a PCI-E bus is commonly referred to as a multiple of one data lane, e.g., "xN" or "Nx" to indicate that the link has N times the bandwidth of a single data lane. PCI-E supports bus sizes of x1, x2, x4, x8, x16, and x32 lanes. Conventionally, a variety of standard connector sizes are utilized, with a x16 connector size being commonly used for graphics cards.

FIG. 2 illustrates a scalable link interface (SLI) graphics system similar to that developed by the Nvidia Corporation of Santa Clara, Calif. A SLI graphics system utilizes two or more graphics cards 130-A and 130-B operating together to produce a single output. That is, the graphics cards process graphics data in parallel. For example, two PCI-E x16 connectors 140-A and 140-B may be provided on the motherboard 100, one for each graphics card 130-A and 130-B. A PCI-E x16 bus (e.g., one x16 bus from a chip 110) is split into two x8 buses, with one x8 bus going to each graphics card. Typically, a switch card 170 (also known as a "paddle card") is provided to determine which of the lanes of the x16 bus from chip 110 are routed to the two PCI-E connectors 140-A and 140-B. The switch card 170 essentially amounts to an additional PCI-E connector which further includes a switching element. This switch card 170 typically has two positions, a first position in which all sixteen lanes from chip 110 are routed to one PCI-E connector (such as PCI-E connector

140-A) and a second switch position in which eight lanes are routed from chip 110 to PCI-E connector 140-A and the other eight lanes from chip 110 are routed to PCI-E connector 140-B. Thus, in an SLI mode each PCI-E connector has half of its serial data lanes coupled to a chipset, while the other half are unused. This results in an inherent compromise in that graphics processing power is increased (because of the two GPUs operating in parallel) but at the cost that each graphics card has half of the PCI-E bandwidth that would be the case if it was used alone.

SLI is typically implemented in a master/slave arrangement in which work is divided up between graphics processors. Software drivers distribute the work of processing graphics data between the two graphics cards. For example, in split frame rendering (SFR), the graphics processing is organized such that an individual frame is split into two different portions, which are processed by the different graphics processors in parallel. In alternate frame rendering (AFR), one graphics card processes the current frame while the other graphics card works on the next frame. In one version, an external SLI connector 180 provides a link between the graphics cards to transmit synchronization and pixel data between the graphics cards.

Recently, quad SLI systems that include four graphics cards have been released by the Nvidia Corporation. A quad SLI system is an extension of SLI in which four graphics cards process graphics data. For example, the work may be split into a combination of AFR and SFR in which groups of two graphics cards work on alternate frames, with each group of two graphics cards in turn performing split frame rendering.

One problem with conventional SLI is that it is more expensive than desired. In particular, extra components, such as switch cards and SLI connectors, are typically required, increasing the cost. Another issue is related to performance caused by splitting the PCI-E bandwidth of chip 110 between two graphics cards. The bandwidth from the chipset to the GPU is reduced by half compared to a single graphics card architecture. This also has the result of limiting the available bandwidth for GPU-to-GPU traffic that flows through the chipset.

As illustrated in FIG. 3, one alternative to conventional SLI would be to use a more expensive set of chips 305, 310 in the chipset to increase the PCI-E bandwidth such that each GPU 320-A and 320-B has a dedicated x16 bandwidth to the chipset. However, in addition to the more expensive chipset that is required, the architecture illustrated in FIG. 3 does not have symmetric data paths 350 and 360 from the CPU 302 to the GPUs. Command streams from the GPU may thus arrive at each GPU at slightly different times. As a result, greater care must be taken in regards to synchronization of the operation of the GPUs 320-A and 320-B than for the case of symmetric data pathways. Alternatively, as illustrated in FIG. 4, a SLI architecture with a more expensive chipset of chips 402 and 404 might be used to increase the PCI-E bandwidth allocated to each GPU 420. For example, chips 404 with a x32 PCI-E interface may be included to support each pair of GPUs 420 with a x16 bus. However, for many market segments the increased performance of adding additional chips or more expensive chips does not justify the additional chip cost.

Therefore in light of the above-described problems the apparatus, system, and method of the present invention was developed.

SUMMARY OF THE INVENTION

A graphics processing unit has a first mode of operation in which the graphics processing unit is operable as an individual graphics processing unit. The graphics processing unit has a second mode of operation in which the graphics processing unit is operable as a set of graphics processing units in which each respective graphics processing unit processes graphics data in parallel with a private bus between the graphics processing units for peer-to-peer communication.

In one embodiment the graphics processing unit includes a bus interface supporting a set of serial data lanes. The bus interface includes a mode controller in which for the first mode of operation the set of serial data lanes are operated as a single bus and for the second mode of operation a first subset of the serial data lanes is managed as one bus and a second subset of the serial data lanes is managed as a private bus for peer-to-peer communication with another graphics processing unit.

BRIEF DESCRIPTION OF THE FIGURES

The invention is more fully appreciated in connection with the following detailed description taken in conjunction with the accompanying drawings, in which:

FIG. 1 illustrates a prior art motherboard of a graphics system with a conventional PCI-E bus;

FIG. 2 illustrates a motherboard of a prior art scalable link interface graphics system having two graphics cards;

FIG. 3 is a block diagram of a prior art graphics system with two GPUs;

FIG. 4 is a block diagram of a prior art graphics system with four GPUs;

FIG. 5 illustrates a motherboard having PCI-E connectors coupled to form a private bus in accordance with one embodiment of the present invention;

FIG. 6 illustrates a motherboard having PCI-E connectors coupled to form a private bus and which includes a switch card in accordance with one embodiment of the present invention;

FIG. 7 illustrates a motherboard having PCI-E connectors coupled by connections formed on the motherboard to define a private bus in accordance with one embodiment of the present invention;

FIG. 8 is a functional block diagram of a graphics system in accordance with one embodiment of the present invention;

FIG. 9 is a block diagram of a quad SLI system in accordance with one embodiment of the present invention;

FIG. 10 is a block diagram of a second embodiment of a quad SLI system in accordance with one embodiment of the present invention;

FIG. 11 illustrates an alternate implementation of the system of FIG. 7 in which a single graphics card is used;

FIG. 12 illustrates an alternate implementation of the system of FIG. 9 in which two graphics cards are utilized; and

FIG. 13 illustrates an alternate implementation of the system of FIG. 10 in which two graphics cards are utilized.

Like reference numerals refer to corresponding parts throughout the several views of the drawings.

DETAILED DESCRIPTION OF THE INVENTION

FIG. 5 is a perspective view of one embodiment of the present invention with some conventional components omit-

ted for clarity and other components not drawn to scale for purposes of illustration. A motherboard 500 includes a chipset which may include a CPU 550 and another chip 540 having a Peripheral Component Interface Express (PCI-E) interface 545. Motherboard 500 has two PCI-E connectors 510 and 515, such as two PCI-E x16 connectors for receiving graphics cards 530-A and 530-B.

Graphics cards 530-A and 530-B have PCI-E connector surfaces 535-A and 535-B designed to mate with a corresponding PCI-E connector 510 or 515. Each graphics card 530-A and 530-B has its own respective graphics processing unit (GPU) 502-A and 502-B. Each graphics card 530-A and 530-B includes internal signal paths (not shown) to couple electrical signals from a PCI-E connector surface 535 to a respective GPU 502-A or 502-B.

An individual PCI-E connector, such as connector 510, has pins 525 and associated internal contact positions 527 of contact fingers, as illustrated in phantom. A PCI-E card-edge connector, such as connector 510 or 515, has contact fingers to accept a card and mate with the contact surfaces of connector surface 535. There are standard PCI-E connector pinouts corresponding to contact positions of contact fingers within the connector. The pinout (and its associated relationship to contact positions) are used to define particular serial data lanes. Thus, for example, a x16 PCI-E connector has a pinout defining sixteen individual simplex receivers and sixteen individual simplex transmitters for the sixteen serial data lanes. The pinout also specifies an assignment of pins (and associated contact positions) to particular data lanes.

In one embodiment, the pins 525 (and their associated contact positions 527) of each connector 510 and 515 are further assigned to either a PCI-E bus (e.g., a PCI-E bus 590 or 595 to chip 540) or to a private bus 580 such as a private bus between graphics cards 530-A and 530-B. PCI-E pinouts are organized with contact positions of transmitters and receivers arranged on two sides of the connector with ascending lane numbers arranged in a sequence along the connector. Thus, specific data lanes are assigned by making electrical connections to specific connector pins (which in turn are coupled to specific internal contact positions defined by the pinout). The P2P arrows illustrate a subset of data lanes assigned to a private bus 580 between connectors 510 and 515. The C1 arrow illustrates a subset of data lanes of connector 515 assigned to a PCI-E bus 595. The C2 arrow illustrates a subset of data lanes of connector 510 assigned to a PCI-E bus 590.

As indicated by the arrows on PCI-E interface 545 of chip 540, in one embodiment the bandwidth of the PCI-E interface of chip 540 is split into two sub-buses coupled to C1 and C2 data lanes. As one example, chip 540 may be part of a chipset based on the nForce4® chipset design of the Nvidia Corporation of Santa Clara, Calif. The nForce4® chipset permits a chipset PCI-E interface 545 to have its serial data lanes configured as either one x16 PCI-E bus or as two x8 PCI-E buses.

A private bus 580 connecting the P2P serial data lanes of connectors 510 and 515 provides a high data rate card-to-card bus. Investigations by the inventor indicate that GPU-to-GPU traffic constitutes a large fraction of the traffic in a SLI mode. Thus, a private bus formed between the P2P serial data lanes of two graphics cards may be used to improve performance. In one embodiment the PCI-E interface 545 of the chipset is a x16 PCI-E interface and each connector 510 and 515 is a PCI-E x16 connectors that has its serial data lanes assigned such that eight serial data lanes are allocated towards P2P and the eight other serial data lanes are allocated for communication with a chipset (i.e., as either C1 or C2 data lanes). How-

ever, it will be understood that these numbers are exemplary and that the more general case is that the private bus includes at least one serial data lane.

A private bus **580** between graphics cards **530-A** and **530-B** formed from P2P serial data lanes should be electrically compatible with PCI-E but may use PCI-E protocols or other protocols, such as a proprietary protocol. Illustrative examples of traffic carried by the private bus include synchronization data, pixel data, and message data. Other examples include cross-blit traffic for texture filtering. Additionally, since the private bus may be used to send specialized traffic between graphics cards, the data compression techniques may be chosen based on the type of data that is sent over the private bus.

Referring to FIG. 6, in one embodiment a switch card **570** may be included to route some or all of the signals between connector pins of connectors **510** and **515**. In this embodiment, the corresponding PCI-E pins of chip **540** are also wired to switch card **570**. Switch card **570** then performs a routing function to help form buses **580**, **590**, and **595** for an SLI-mode. However, a switch card **570** adds an additional expense. Thus, the embodiment of FIG. 6 may have a cost that is higher than desired for many applications.

FIG. 7 illustrates an embodiment including a custom motherboard **700**. Custom motherboard **700** includes electrical interconnections (illustrated in phantom) for private bus **580** to electrically couple P2P pins (not shown) of connectors **510** and **515**. Custom motherboard **700** also includes electrical interconnections (illustrated in phantom) to electrically couple corresponding pins (not shown) of connectors **510** and **515** with pins (not shown) of chip **540** to form buses **590** and **595**. Techniques to pattern electrical interconnections onto a motherboard are well known in the electronics packaging art. However, the electrical interconnections used to form buses **580**, **590**, and **595** are preferably fabricated to be compatible with the high data rates of PCI-E. The electrical interconnections formed in the motherboard for each bus **580**, **590**, and **595** may, for example, include hard-wired high speed simplex connections patterned onto motherboard **700** in a manner compatible with the low-voltage differential signaling used in PCI-E. Thus, for example, if a sub-bus, such as private bus **580**, has eight serial data lanes the motherboard may have high-speed interconnections to support eight dual simplex connections of the eight serial data lanes. The embodiment of FIG. 7 thus requires a custom motherboard but eliminates the cost of a switching card.

FIG. 8 is a block diagram illustrating in more detail functional components of the graphics system **800**. The system includes software that runs on CPU **550**, such as a BIOS **805** and a driver **820**. An individual GPU, such as GPU **502-A**, is preferably designed to have a default mode in which it acts as the sole GPU in some applications but is also configurable for use with other graphics cards for multi-graphics card SLI architectures. A configuration process is used to configure two GPUs **502-A** and **502-B** for SLI. In an SLI mode, driver **820** generates commands for both GPUs **502-A** and **502-B** to render different portions of frames (e.g., SFR). Each GPU **502-A** and **502-B** may also have SLI mode information **840** configured during a setup process.

In one embodiment, a PCI-E mode of each GPU **502-A** and **502-B** is also configured during a setup operation. Each GPU **502** includes a PCI-E physical interface **850** that includes transmitter and receiver pairs **801** to support serial data lanes, a PCI-E controller **860**, a bus mode control module **865**, and a logical channel module **870**. In the PCI Express specification each point-to-point link between components may have 1, 2, 4, 8, 12, 16, or 32 dual simplex 2.5 Gbps lanes. PCI

Express calls for 8 bit/10 bit data encoding to create a 2 differential pair, 2.5 Gbps (2.0 Gbps effective rate) dual simplex data stream with an embedded clock for each data lane. The PCI Express specification has a default that specifies that the link width is negotiated to the maximum link width supported by both sides of the bus. A link state machine executes the states of a link training and status state machine (LTSSM) specified by the PCI Express specification.

In the embodiment of FIG. 8, each rendering mode also has an associated bus interface mode, depending on the number of graphics cards used to render the frame and the manner in which the rendering of frame data is allocated to different graphics cards. Mode control module **865** may for example, be configured by a register write in a BIOS configuration step. Logical channel module **870** logically partitions the available serial data lanes into one or two channels, depending upon the operating mode. The logical channel module **870** has a first mode in which all of the serial data lanes of the physical interface **850** are considered to be part of a conventional PCI-E bus. The logical channel module has a second mode of operation in which the serial data lanes of the PCI-E physical interface **850** are logically partitioned into a first bus channel including a first subset of serial data lanes and a second bus channel having a second subset of serial data lanes. Thus, the two different supported modes permit a graphics card to be used either as a single card (with all serial data lanes used as one PCI-E bus) or for SLI with a subset of the serial data lanes used as a private GPU-to-GPU bus. Note that the functionality of mode control module **865** and logical channel module **870** may be integrated into PCI-E controller **860**.

The logical partitioning of the physical interface **850** may utilize the same bus protocol (e.g., PCI-E) or different protocols. For example, one of the channels may use PCI-E and the other may use a proprietary protocol. Each channel may, for example, have its own state machine for configuring a link using the protocol selected for the channel.

It is desirable that graphics system **800** account for differences in data latency along different data pathways when SLI is used. Note that graphics system **800** has several different data pathways. These include a private bus **892** and also buses **894** and **896** between individual GPUs and chip **540**. Thus, depending upon implementation details, some GPU-to-GPU traffic may be sent directly on private bus **892** whereas other GPU-to-GPU traffic may be sent via buses **894** and **896** through chip **540**. Additionally, depending upon implementation details, other types of traffic may also take different routes, depending upon whether private bus **892** is used.

Some types of traffic in graphics system **800** may have a semantic order. That is, certain types of data traffic may require a critical order of the traffic be maintained (with respect to other events and/or traffic) in order for the data to be properly interpreted. As previously described, in a SLI architecture CPU **550** issues command streams to the GPUs **502-A** and **502-B** to divide work between GPUs **502-A** and **502-B**. Additionally for certain types of graphics operations, one GPU **502-A** may have to transfer data to another GPU **502-B** for additional processing. As result, some types of traffic may require maintaining a semantic order. In some circumstances, there is a possibility that some types of traffic received by one GPU **502** over private bus **892** may arrive in an order slightly different than an ideal semantic order due to the differences in propagation time of the different data paths when SLI is used. A reordering module **885** is preferably provided to provide any necessary reordering to ensure proper semantic ordering of traffic regardless of the pathway that the traffic takes. For example, reordering module **885** may include a first-in, first-out (FIFO) buffer and reorder logic to reorder traffic into a

proper semantic order. Alternatively, in one embodiment, each GPU **502-A** and **502-B** is configured to direct traffic in a manner selected to avoid sending traffic over private bus **892** that is critically dependent on semantic order.

As previously described, one benefit of the present invention is that the private bus may be used for GPU-to-GPU communication. Investigations by the inventor indicate that there is substantial GPU-to-GPU traffic in typical SLI architecture. In a conventional low-cost implementation of SLI this GPU-to-GPU traffic is typically routed through the chipset. In contrast, one embodiment of the present invention utilizes serial data lanes which would conventionally be unused to form the private bus. For SLI systems in which there is a substantial amount of GPU-to-GPU traffic, the private bus allows a low-cost solution to achieve performance comparable to more expensive solutions. Additionally, as previously described, in one embodiment the private bus is implemented in a fashion that eliminates the need for a switch card **170** and external SLI connector **180**, resulting in potential cost savings.

It is contemplated that the present invention may be utilized in a variety of different SLI architectures. It will be understood that embodiments of the present invention also include quad SLI systems having four GPUs. As illustrated in FIGS. **9** and **10**, for a high performance quad SLI system a more complicated chipset may be used to support four GPUs, with pairs of two GPUs having a private bus as previously described. For example, in the block diagram of FIG. **9**, the chipset has a CPU **550**, intermediate chip **905**, and fans out to two chips **920**, each with a $\times 16$ PCI-E interface. Four GPUs **930** are supported, with the system supporting a $\times 8$ private bus **950** between each pair of GPUs. FIG. **10** illustrates an architecture in which a chip **1020** has a $\times 32$ PCI-E interface, such that it can support four GPUs **930** with $\times 8$ PCI-E buses.

In some applications it is desirable to provide options for configuring a graphics system with different numbers of graphics cards while making the best use of the available PCI-E bandwidth to the chipset. For example, referring again to the graphics system of FIG. **7**, two graphics cards **530-A** and **530-B** are illustrated. However, it may be desirable to provide the option to utilize custom motherboard **700** in a configuration in which only a single graphics card **530-A** is utilized with the full PCI-E bus bandwidth of PCI-E interface **545** available to graphics card **530-A**. FIG. **11** illustrates custom motherboard **700** with only a single graphics card **530-A**. In the example of FIG. **11**, a printed circuit board (PCB) **1105** is installed in connector **515**. PCB **1110** includes a bridge section **1110** having interconnects to bridge **C1** data lanes with respective P2P data lanes. As a consequence, both **C1** and **C2** data lanes are available to support traffic between chip **540** and graphics card **530-A** such that graphics card **530-A** can utilize the full bandwidth of the PCI-E bus.

In one embodiment, a graphics system supports SLI operation with different numbers of graphics cards, such as SLI operation with either two graphics cards or four graphics cards. FIG. **12** illustrates an implementation of the system of FIG. **9** in which one of the GPUs **930** in each pair is replaced with a PCB **1105**. As a result, each individual GPU **930** in the implementation of FIG. **12** has the full PCI-E $\times 16$ bandwidth. Thus comparing FIGS. **9** and **12**, the same system can be used to support either two graphics cards (FIG. **12**) or four graphics cards (FIG. **9**). Similarly, as illustrated in FIG. **13**, the system of FIG. **10** may also be implemented with one of the GPUs **930** in each pair replaced with a PCB **1105**.

While PCI-E is a commonly used bus in the graphics industry, it will be understood that the present invention may be applied to other types of buses in which a set of serial data

lanes may be logically partitioned. In addition, it will be understood that the present invention may be applied to private buses between entities other than graphics cards, such as a private bus providing a card-to-card link for other types of cards besides graphics cards.

While examples have been described with a GPU, more generally it will be understood that the present invention may also be applied to General Purpose GPUs (GPGPUs).

An embodiment of the present invention relates to a computer storage product with a computer-readable medium having computer code thereon for performing various computer-implemented operations. The media and computer code may be those specially designed and constructed for the purposes of the present invention, or they may be of the kind well known and available to those having skill in the computer software arts. Examples of computer-readable media include, but are not limited to: magnetic media such as hard disks, floppy disks, and magnetic tape; optical media such as CD-ROMs and holographic devices; magneto-optical media such as floptical disks; and hardware devices that are specially configured to store and execute program code, such as application-specific integrated circuits ("ASICs"), programmable logic devices ("PLDs") and ROM and RAM devices. Examples of computer code include machine code, such as produced by a compiler, and files containing higher-level code that are executed by a computer using an interpreter. For example, an embodiment of the invention may be implemented using Java, C++, or other object-oriented programming language and development tools. Another embodiment of the invention may be implemented in hardwired circuitry in place of, or in combination with, machine-executable software instructions.

The foregoing description, for purposes of explanation, used specific nomenclature to provide a thorough understanding of the invention. However, it will be apparent to one skilled in the art that specific details are not required in order to practice the invention. Thus, the foregoing descriptions of specific embodiments of the invention are presented for purposes of illustration and description. They are not intended to be exhaustive or to limit the invention to the precise forms disclosed; obviously, many modifications and variations are possible in view of the above teachings. The embodiments were chosen and described in order to best explain the principles of the invention and its practical applications, they thereby enable others skilled in the art to best utilize the invention and various embodiments with various modifications as are suited to the particular use contemplated. It is intended that the following claims and their equivalents define the scope of the invention.

The invention claimed is:

1. A graphics system, comprising:

a graphics processing unit having a first mode of operation in which said graphics processing unit is operable as an individual graphics processing unit and a second mode of operation in which said graphics processing unit is operable as part of a set of graphics processing units in which each respective graphics processing unit processes graphics data in parallel;

a bus interface disposed in said graphics processing unit, said bus interface supporting a set of serial data lanes; and

said bus interface including a mode controller in which for said first mode of operation said set of serial data lanes is operated as a single bus and for said second mode of operation a first subset of said serial data lanes is managed as one bus and a second subset of said serial data

9

lanes is managed as a private bus for peer-to-peer communication with another graphics processing unit; said graphics processing unit in said second mode of operation having at least two data paths for directing traffic to said another graphics processing unit including a first data path via said private bus and a second data path via said one bus through a chipset to said another graphics processing unit;

5 said graphics processing unit configured to direct traffic to said another graphics processing unit to avoid sending traffic over said private bus that has a semantic order in which an interpretation of data is critically dependent on an order of the data such that said private bus is utilized to send data in which the order that the data is received is not critical.

10 2. The graphics system of claim 1, wherein said graphics processing unit utilizes said private bus as a pixel bus.

3. The graphics system of claim 1, wherein said graphics processing unit sends data on said private bus in a compressed format.

15 4. The graphics system of claim 1, wherein said private bus is utilized by said graphics processing unit to send cross-blit data.

5. The graphics system of claim 1, wherein said second mode of operation corresponds to split frame rendering in which two graphics processing units split the rendering of individual frames.

20 6. The graphics system of claim 1, wherein at least one serial data lane of said bus interface of said graphics processing unit is coupled to a chipset.

7. A graphics system, comprising:

a first graphics processing unit (GPU) having a first bus interface managing a first plurality of serial data lanes;

a second GPU having a second bus interface managing a second plurality of serial data lanes;

25 a chipset having a third bus interface managing a third plurality of serial data lanes; and

said graphics system partitioning said third plurality of serial data lanes into a first set of serial data lanes coupling said chipset and said first bus interface and a second set of serial data lanes coupling said chipset and said

40

10

second bus interface with the remaining serial data lanes of said first bus interface and said second bus interface configured as a private bus between said first GPU and said second GPU such that there are at least two data paths for traffic between said first GPU and said second GPU including a first data path associated with said private bus and a second data path associated with routing traffic between said first GPU and said second GPU via said chipset;

10 said graphics system configured to direct traffic between said first GPU and said second GPU to avoid sending traffic over said private bus that has a semantic order in which an interpretation of data is critically dependent on an order of the data such that said private bus is utilized to send data in which the order that the data is received is not critical.

15 8. The graphics system of claim 7, wherein said private bus is utilized as a pixel bus.

9. The graphics system of claim 7, wherein said graphics data is sent on said private bus in a compressed format.

20 10. The graphics system of claim 7, wherein said private bus is utilized by at least one of said graphics processing units to send cross-blit data.

11. The graphics system of claim 7, wherein said graphics systems is configured to perform split frame rendering in which two graphics processing units split the rendering of individual frames.

25 12. The graphics system of claim 1, wherein said first bus interface includes a logical channel module that logically partitions said first bus interface to support communication with the chipset and to support the private bus.

30 13. The graphics system of claim 12, wherein said graphics system logically partitions a sixteen lane Peripheral Component Interface Express (PCI-E) bus into eight lanes for communication with said chipset and eight lanes for said private bus.

35 14. The graphic system of claim 7, wherein said private bus is used for peer-to-peer communication between said graphics processing units.

* * * * *